

GLASS IS LIFE™

 makers of pure, sustainable, brand-building glass packaging

O-I Sales and Distribution Italy s.r.l.

Via 1° Maggio, 18
21040 Origgio(VA), Italy
Tel. +39 0243453.1

CONTAINER & MOULD ENGINEERING

EUROPE

NOTES:
THIS DRAWING IS THE PROPERTY OF O-I AND MUST NOT BE REPRODUCED OR DISCLOSED WITHOUT O-I WRITTEN AUTHORIZATION.

ONLY TOLERANCED DIMENSIONS ARE GUARANTEED.

MANUFACTURING MARKINGS SHOWN ARE FOR ILLUSTRATIVE PURPOSES ONLY, ACTUAL MARKINGS ON CONTAINER MAY DIFFER, DEPENDANT ON LOCAL LEGISLATION.

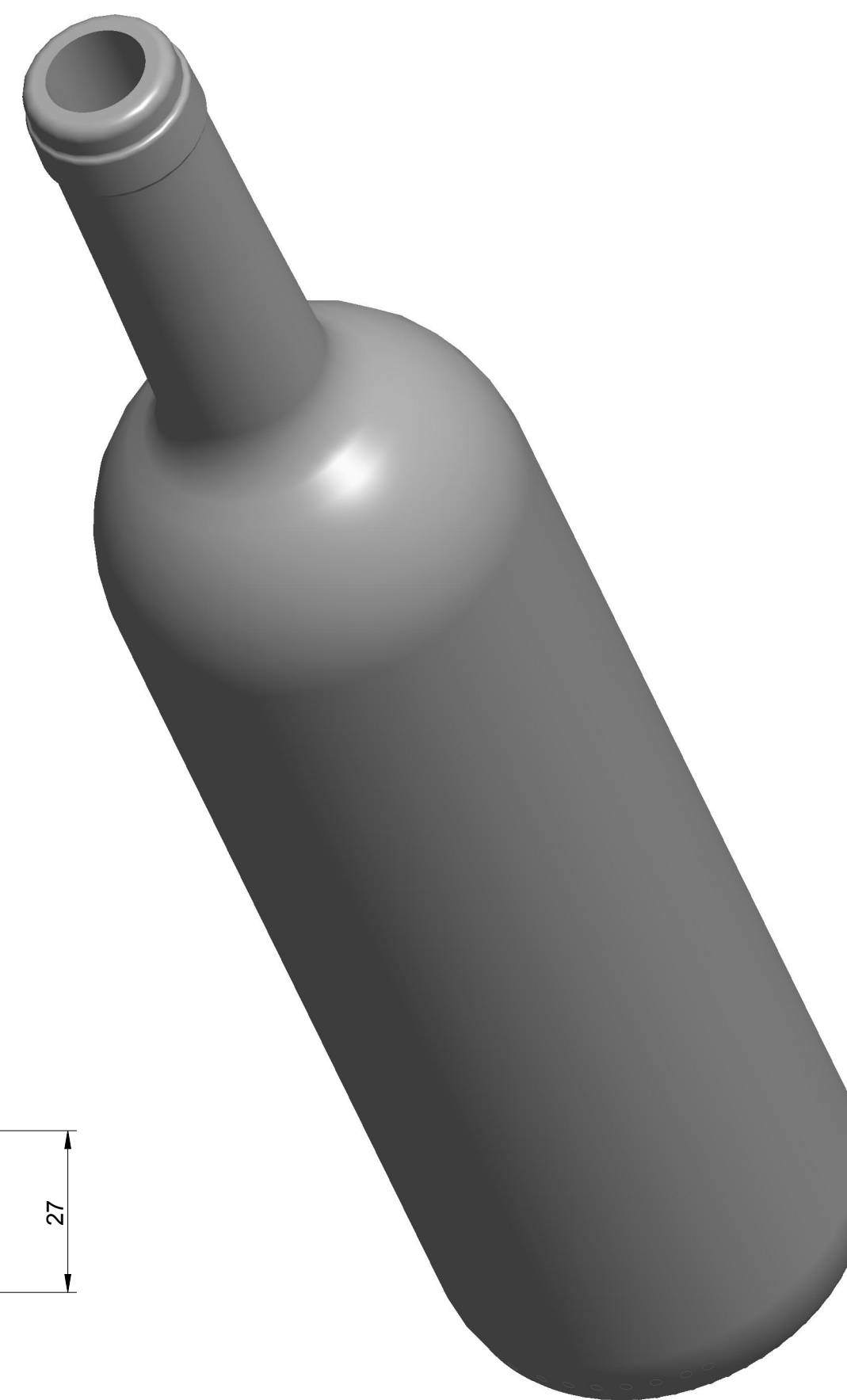
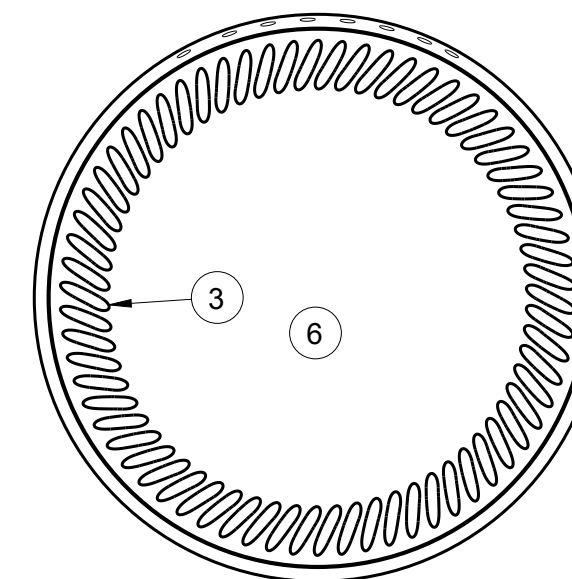
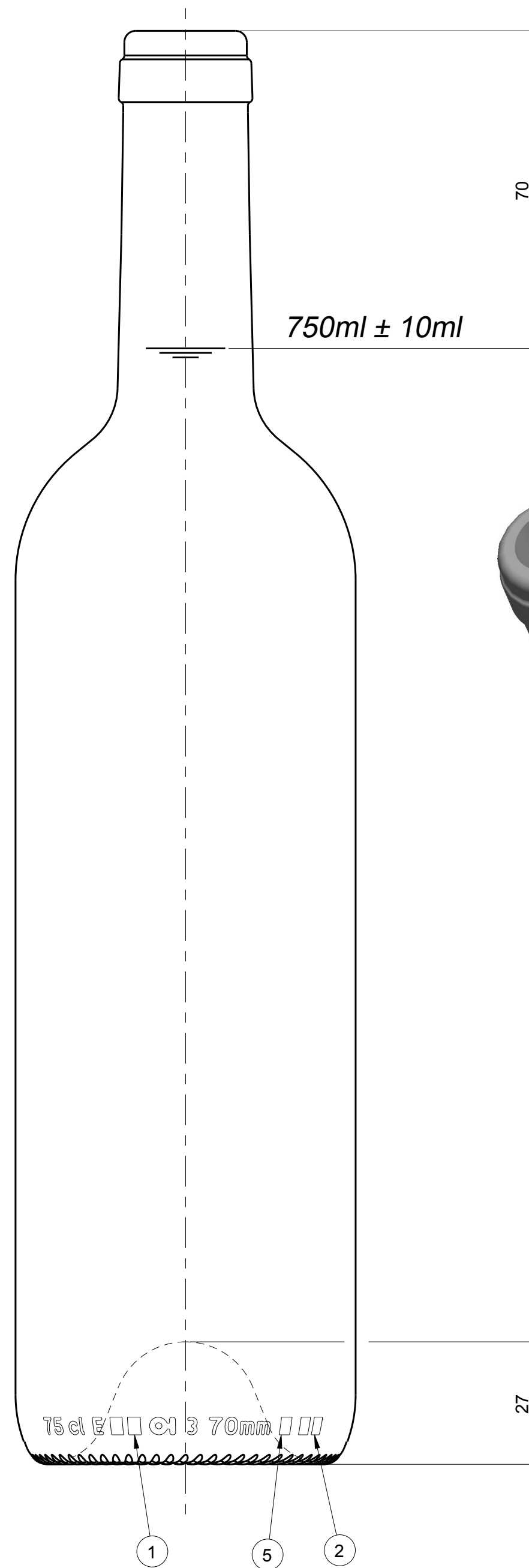
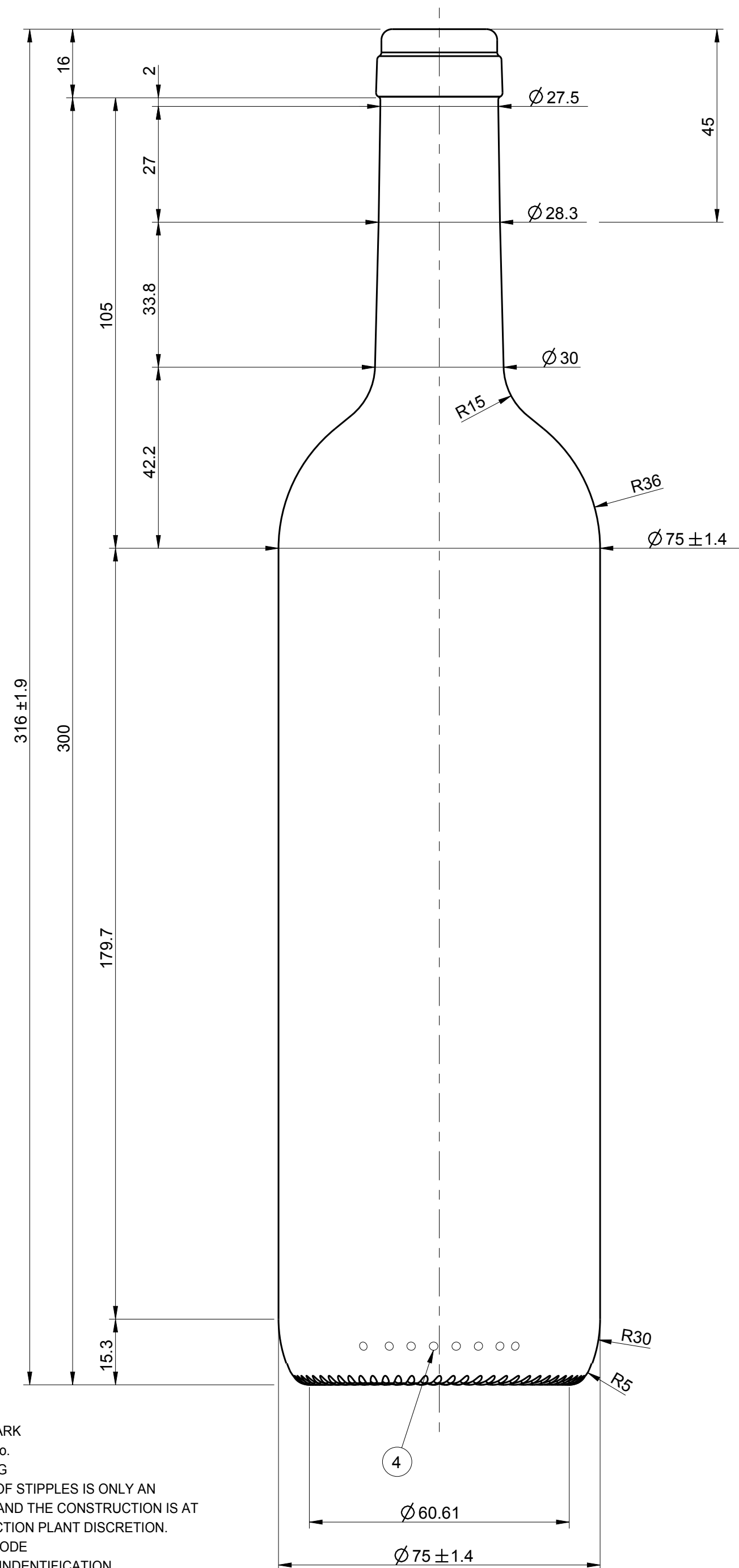

- 1 = TRADEMARK
- 2 = CAVITY No.
- 3 = STIPPLING
- THE SHAPE OF STIPPLES IS ONLY AN INDICATION AND THE CONSTRUCTION IS AT THE PRODUCTION PLANT DISCRETION.
- 4 = CAVITY CODE
- 5 = A GLASS INDENTIFICATION
- 6 = KNURLING AT PLANT DISCRETION

SCALE 1:1

CATEGORY WINE		TILT ANGLE 14.56°	
MAX. VERTICALITY TOLERANCE 3.5 mm		MEASURING CONTAINER YES	
FINISH SAP NUMBER 0775		FINISH REF. SPECIAL	
MINIMUM THROUGH BORE 16.0 mm		MAX FILLING TUBE Ø 14.5mm	
CONTAINER OVERFLOW CAPACITY (BRIMFUL)			
770ml APPROX.			
CONTAINER RATED CAPACITY (FILLPOINT)			
750ml ± 10ml			
CONTAINER WEIGHT			
540g APPROX.			
FINISH DESIGNATION IT_29.5_SPECIAL_H160_0775		MAX GAS VOLUME 4 g/l co2	
PROCESS	RETURNABLE NO	DESIGN REF. IPISO 6471	
STANDARD			
75 cl BD Selecta TS			
DESIGNER	CD	DATE	29.05.12
CHECKED		DATE	
DRAWING NUMBER 120356		MOULD/SAP NUMBER 120356	

	20/10/16	UPDATED HEADSPACE AS PRODUCTIONS	LL
1	14/06/12	ADDED SHAPE CODE , RENAMED CONTAINER , MOVED FILL POINT HEIGHT ON HELL	I.B.
No	DATE	REVISIONS	DESIGN/CHECK