

GLASS IS LIFE™

O-I makers of pure, sustainable,
brand-building glass packaging

O-I GLASSPACK GmbH & co. KG

Goethestrasse 75
40237 Düsseldorf, Germany
Tel. +49 0211/2809-0
+49 0211/932-0

**CONTAINER & MOULD ENGINEERING
EUROPE**

NOTES:
THIS DRAWING IS THE PROPERTY OF O-I AND
MUST NOT BE REPRODUCED OR DISCLOSED
WITHOUT O-I WRITTEN AUTHORIZATION.

ONLY TOLERANCED DIMENSIONS ARE GUARANTEED.

MANUFACTURING MARKINGS SHOWN ARE FOR ILLUSTRATIVE
PURPOSES ONLY. ACTUAL MARKINGS ON CONTAINER
MAY DIFFER, DEPENDANT ON LOCAL LEGISLATION.

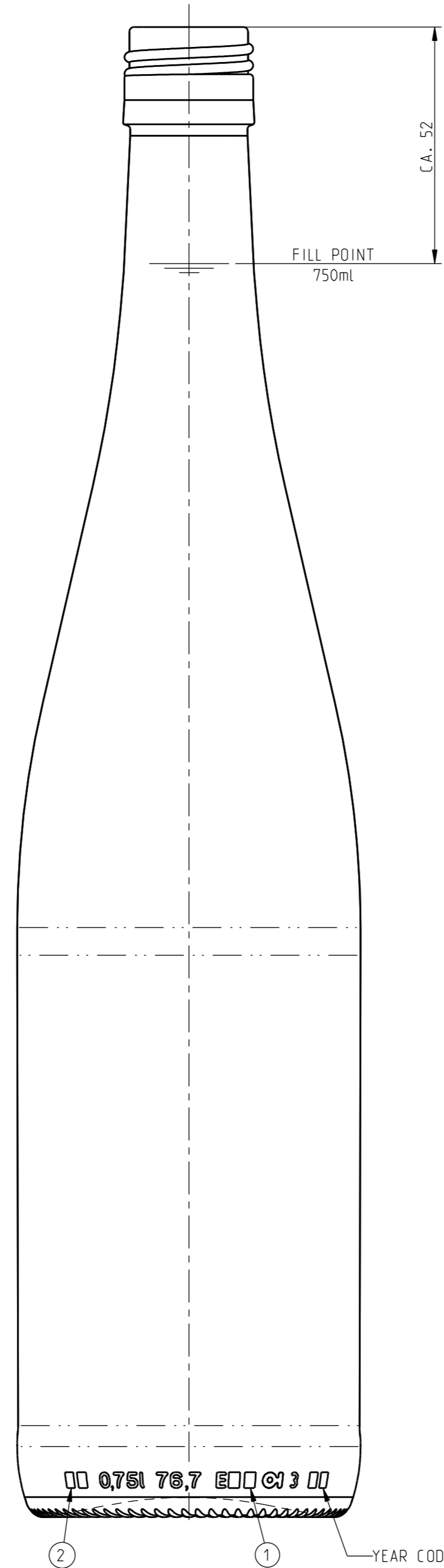
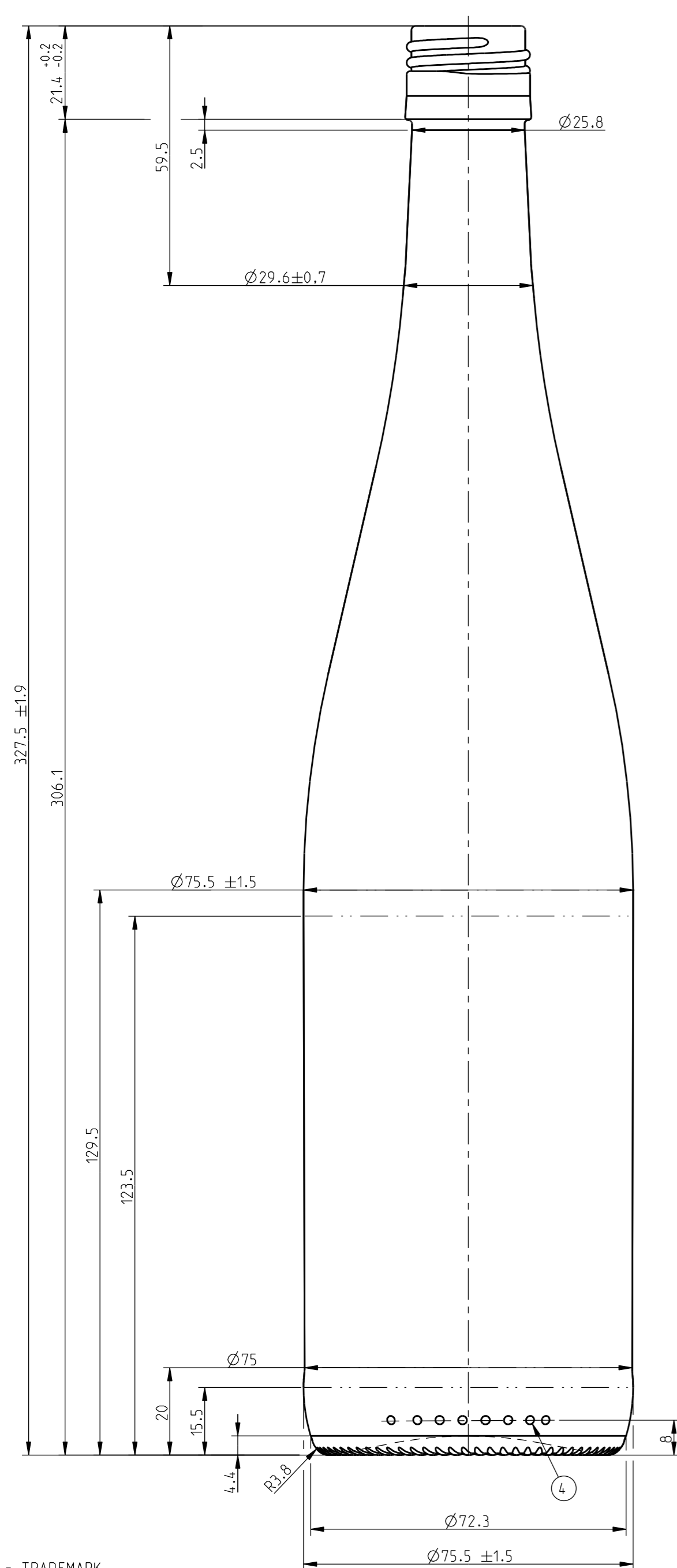

This detail only serves for the approximation of the attitude of the filling machine. the brimfull capacity remains binding

FILL POINT
750ml

CA. 52

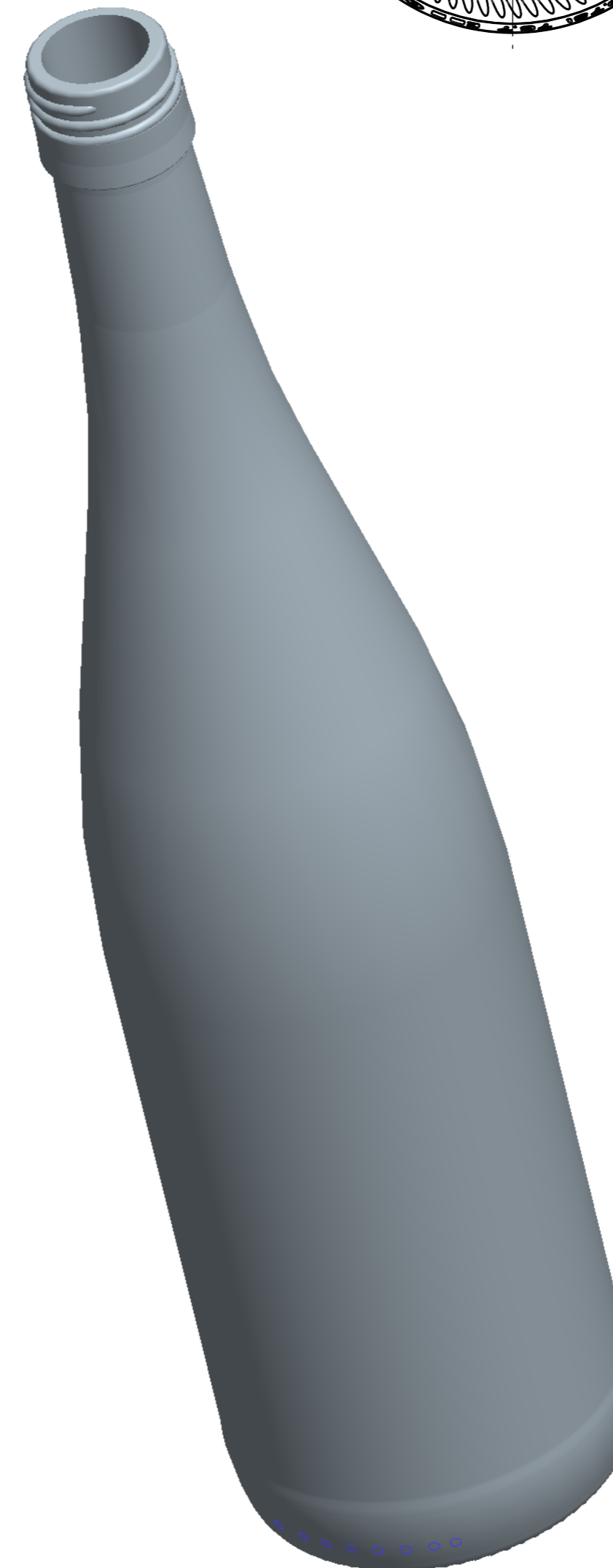
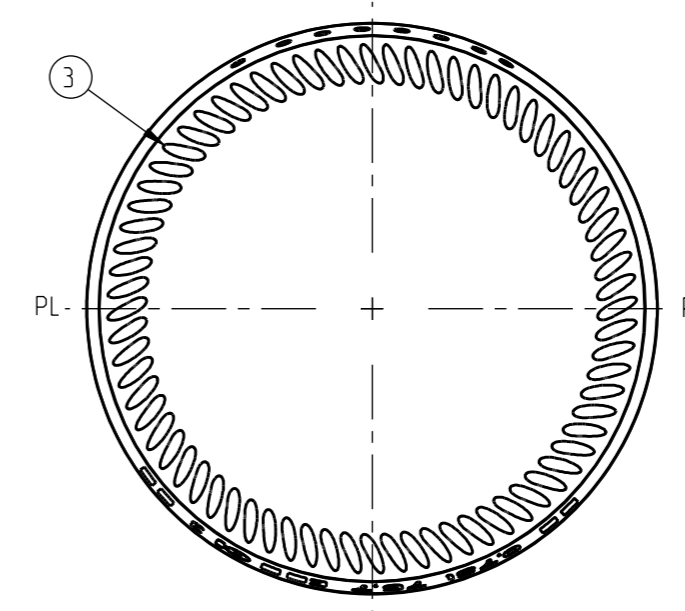

- 1 = TRADEMARK
- 2 = CAVITY No.
- 3 = STIPPLING
- 4 = CAVITY CODE

SCALE 1:1

TENTATIVE

No	DATE	REVISIONS	DESIGN/CHECK

INTERNAL PRESSURE RESISTANCE	
max. 6 bar	
CATEGORY WINE	TILT ANGLE 13.89°
MAX. VERTICALITY TOLERANCE ± 3.6 mm	MEASURING CONTAINER YES
FINISH SAP NUMBER 4408	FINISH REF. CETIE GME 30.13 2007
MINIMUM THROUGH BORE 17.0 mm	MAX FILLING TUBE Ø 15.5 mm
CONTAINER OVERFLOW CAPACITY (BRIMFUL)	
767ml ± 10ml	
CONTAINER RATED CAPACITY (FILLPOINT)	
750ml	
CONTAINER WEIGHT	
440g APPROX.	
FINISH DESIGNATION DE_30_GME 30.13_H218_4408	MAX GAS VOLUME
PROCESS	RETURNABLE
NO	DESIGN REF. 090046
various customers 0,75l Schlegelflasche	
DESIGNER	J.B.
DATE	01.02.2012
CHECKED	S.Mo.
DATE	13.03.2012
DRAWING NUMBER 120082	MOULD/SAP NUMBER 120082